

# LHR SERIES-HIGH RATE

## LHR12700FT (12V700W)

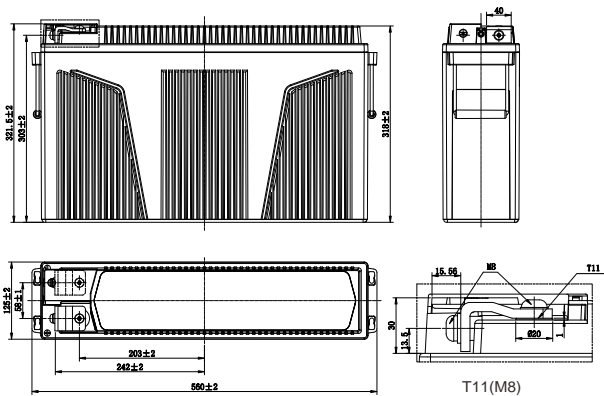

### CHARACTERISTICS

Item	Specifications	
Rated Voltage	12V	
Nominal Rate (25°C)	$W_{15}, 1.67V/cell$	700W/cell
Nominal Capacity (25°C)	$C_{10}, 1.80V/cell$	180Ah
Dimension	Length	560mm (22.0inches)
	Width	125mm (4.92inches)
	Container Height	318mm (12.5inches)
	Total Height	321.5mm (12.7inches)
Approx Weight	60.0kg (132.3lbs)	
Terminal	T11(M8)	
Container Material	ABS (UL94 HB or V-0 optional)	
Short-circuit current	3600A	
Internal Resistance (25°C)	Approx 3.2 mΩ (Fully charged)	
Operating Temp. Range	Discharge	-20~55°C (-4~131°F)
	Charge	-20~40°C (-4~104°F)
	Storage	-15~50°C (5~122°F)
Nominal Operating Temp. Range	25±3°C (77±5°F)	
Max.Charging Current (25°C)	0.25C	
Charge voltage (25°C)	Float Charge	Equalization Charge
	2.25-2.30V/cell	2.30-2.40V/cell
Temp. Coefficient	-3mV/cell/°C	-4mV/cell/°C
	40°C (104°F)	106%
Effect of temp. to Capacity	25°C (77°F)	100%
	0°C (32°F)	86%
	Self Discharge	≤ 3% per month at 25°C (77°F)

### DISCHARGE TABLE

Constant Current Discharge (Amperes) at 25°C (77°F)														
F.V/Time	5min	10min	15min	20min	30min	45min	1h	1.5h	2h	3h	4h	5h	8h	10h
1.85V/cell	409.5	328.3	282.5	222.1	162.3	122.4	95.0	73.9	59.5	44.3	35.0	29.6	20.5	17.5
1.80V/cell	467.0	373.7	321.0	251.8	183.5	127.8	97.2	78.5	63.0	46.4	36.3	30.8	20.9	18.0
1.75V/cell	513.5	410.3	351.8	275.2	199.8	134.6	100.8	81.6	65.4	48.0	37.5	31.7	21.1	18.1
1.70V/cell	543.6	433.2	370.0	289.0	209.8	140.0	106.0	83.7	67.0	49.0	38.4	32.4	21.4	18.2
1.67V/cell	574.3	456.2	388.7	303.0	219.3	144.4	110.2	85.8	68.6	50.0	38.9	32.8	21.7	18.5
1.60V/cell	594.6	471.8	400.7	310.8	224.6	149.4	113.1	87.4	69.9	51.3	39.8	33.5	21.8	18.6

Constant Power Discharge (Watts/cell) at 25°C (77°F)														
F.V/Time	5min	10min	15min	20min	30min	45min	1h	1.5h	2h	3h	4h	5h	8h	10h
1.85V/cell	764.8	617.7	534.8	422.5	310.2	235.3	183.8	143.3	115.7	86.6	68.7	58.4	40.7	34.8
1.80V/cell	857.9	692.9	599.9	473.9	347.9	244.1	187.0	151.4	121.9	90.2	71.0	60.4	41.4	35.7
1.75V/cell	926.9	748.7	648.2	512.1	376.0	255.6	193.0	156.7	126.1	93.0	73.1	61.9	41.7	35.9
1.70V/cell	965.0	779.4	674.8	533.1	391.4	264.0	201.9	159.9	128.6	94.7	74.6	63.2	42.3	36.1
1.67V/cell	1001.0	867.0	700.0	553.0	406.0	270.8	208.8	163.1	131.1	96.2	75.3	63.8	42.6	36.6
1.60V/cell	1015.0	909.8	709.8	560.7	411.7	277.5	212.7	165.0	132.8	98.1	76.7	64.8	42.8	36.7

# LHR SERIES-HIGH RATE

## LHR12700FT (12V700W)



### APPLICATIONS

- UPS
- Hospitals and Testing Laboratories
- Emergency Power Supply
- Industrial Process Control Facilities
- Banks and Financial Markets
- Data and Network Operation Centers

### GENERAL FEATURES

- 12+ years design life (25°C)
- Excellent high current performance - optimised for short discharge time
- Advanced AGM technology for superior high-rate power
- Long Life Alloy - minimizing grid growth, reducing gassing, and extending battery life
- Optimal energy density - saves floor space
- Front access design for easy installation and maintenance

### STANDARDS

- Compliance with IEC 60896 standards
- Classified as "Very Long Life" according to Eurobat
- CE,UL Approved
- Manufactured in Leoch@IATF 16949, ISO 45001,ISO 9001 and ISO 14001 certified production facilities

#### Discharge Characteristics

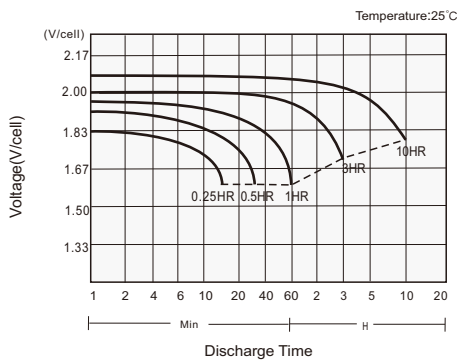

#### Charging Characteristics

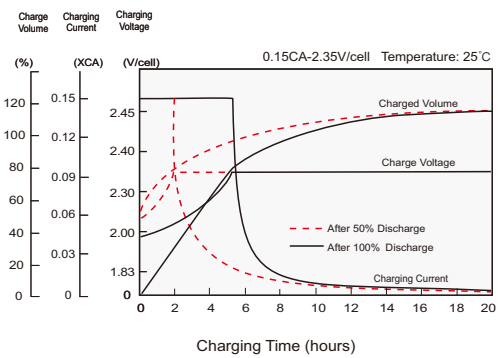

#### Effects of Temperature on Capacity

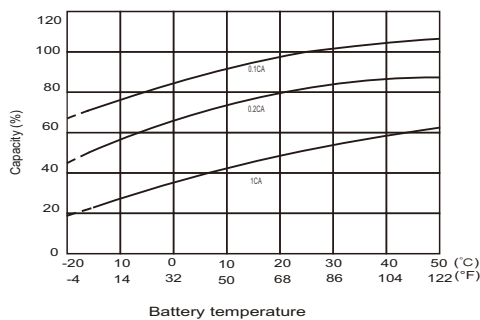

#### Self Discharge Characteristics

