

# LP SERIES-GENERAL PURPOSE

## LP6-7.5 (6V7.5Ah)

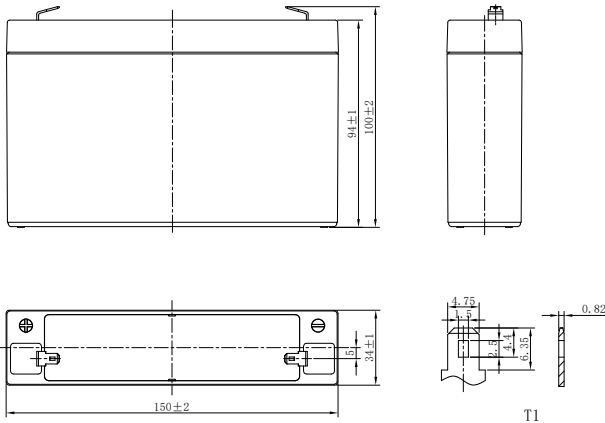

### CHARACTERISTICS

Item	Specifications	
Rated Voltage	6V	
Nominal Capacity (25°C)	C <sub>20</sub> : 1.75V/cell	7.5Ah
Dimension	Length	150mm (5.91inches)
	Width	34mm (1.34inches)
	Container Height	94mm (3.70inches)
	Total Height	100mm (3.94inches)
Approx Weight	1.26kg (2.78lbs)	
Terminal	T1/T2	
Container Material	ABS (UL94 HB or V-0 optional)	
Short-circuit current	210A	
Internal Resistance (25°C)	Approx 20 mΩ (Fully charged)	
Operating Temp. Range	Discharge	-15~50°C (5~122°F)
	Charge	-20~40°C (-4~104°F)
	Storage	-15~40°C (5~104°F)
Nominal Operating Temp. Range	25±3°C (77±5°F)	
Max. Charging Current (25°C)	0.3C	
Charge voltage (25°C)	Standby Use	Cycle Use
	2.25-2.30V/cell	2.35-2.45V/cell
Temp. Coefficient	-3mV/cell/°C	
	-5mV/cell/°C	
Effect of temp. to Capacity	40°C (104°F)	103%
	25°C (77°F)	100%
	0°C (32°F)	86%
Self Discharge	≤3% per month at 25°C (77°F).	
	LP series batteries may be stored up to 6 months at 25°C (77°F) and then a freshening charge is required. For higher temperatures the time interval will be shorter.	

### DISCHARGE TABLE

Constant Current Discharge (Amperes) at 25°C (77°F)																
F.V/Time	5min	10min	15min	20min	30min	45min	1h	1.5h	2h	3h	4h	5h	6h	8h	10h	20h
1.85V/cell	23.4	16.0	11.9	10.1	7.45	5.37	4.37	3.18	2.46	1.75	1.38	1.20	1.04	0.826	0.682	0.367
1.80V/cell	25.2	17.0	12.5	10.5	7.68	5.52	4.48	3.25	2.51	1.78	1.40	1.22	1.05	0.838	0.693	0.371
1.75V/cell	26.6	17.6	12.9	10.8	7.88	5.64	4.57	3.31	2.56	1.81	1.42	1.23	1.07	0.848	0.702	0.375
1.70V/cell	27.8	18.3	13.4	11.1	8.08	5.76	4.65	3.36	2.59	1.84	1.44	1.25	1.08	0.860	0.709	0.378
1.67V/cell	28.8	18.9	13.7	11.4	8.22	5.86	4.72	3.41	2.62	1.86	1.45	1.26	1.09	0.869	0.717	0.381
1.60V/cell	30.5	19.7	14.2	11.7	8.45	6.00	4.83	3.48	2.68	1.89	1.48	1.27	1.11	0.878	0.722	0.385
Constant Power Discharge (Watts/cell) at 25°C (77°F)																
F.V/Time	5min	10min	15min	20min	30min	45min	1h	1.5h	2h	3h	4h	5h	6h	8h	10h	20h
1.85V/cell	44.4	30.4	22.9	19.5	14.4	10.4	8.50	6.21	4.83	3.45	2.72	2.37	2.06	1.63	1.35	0.733
1.80V/cell	47.2	32.0	23.9	20.2	14.8	10.7	8.68	6.32	4.90	3.50	2.75	2.40	2.07	1.65	1.38	0.742
1.75V/cell	49.2	33.1	24.5	20.6	15.1	10.9	8.83	6.42	4.98	3.54	2.78	2.42	2.10	1.68	1.39	0.750
1.70V/cell	51.1	34.2	25.2	21.1	15.4	11.1	8.96	6.51	5.04	3.59	2.82	2.45	2.13	1.70	1.41	0.756
1.67V/cell	52.4	34.9	25.7	21.5	15.6	11.2	9.08	6.58	5.09	3.62	2.84	2.48	2.16	1.72	1.42	0.762
1.60V/cell	54.5	36.0	26.4	22.0	16.0	11.4	9.24	6.69	5.17	3.68	2.88	2.51	2.18	1.74	1.43	0.770

# LP SERIES-GENERAL PURPOSE

## LP6-7.5 (6V7.5Ah)



### APPLICATIONS

- Uninterruptable Power Supply (UPS)
- Electric Power System (EPS)
- Emergency backup power supply
- Alarm and security system
- Communication power supply
- DC power supply
- Auto control system

### GENERAL FEATURES

- 5 years design life (25°C)
- Lead calcium alloy, sealed design, no watering required
- Puncture resistant micro-porous glass mat separators extend life
- Unique technology optimizes power capacity, cell consistency, and long-term reliability
- Designed for a wide range of applications

### STANDARDS

- Compliance with IEC 60896 standards, EU Battery Directive
- UL, CE Approved
- Manufactured in Leoch@IATF 16949, ISO 45001, ISO 9001 and ISO 14001 certified production facilities

#### Discharge Characteristics

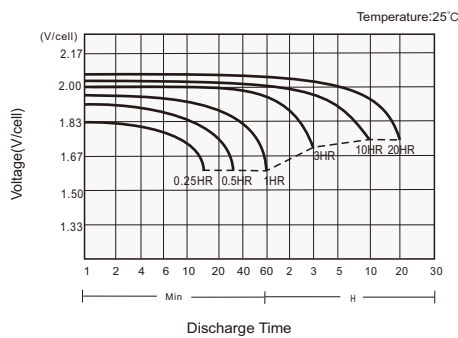

#### Charging Characteristics

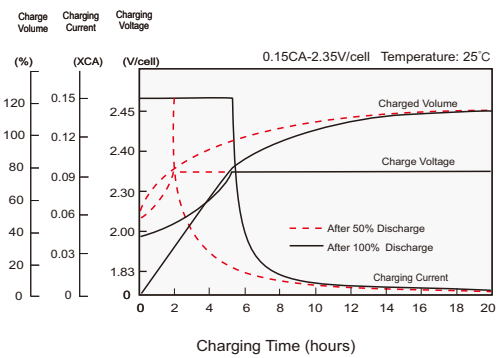

#### Effects of Temperature on Capacity

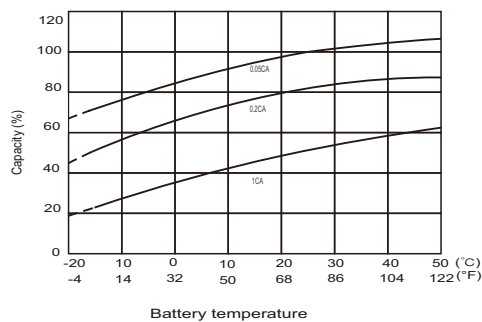

#### Self Discharge Characteristics

